

ABB MEASUREMENT & ANALYTICS | DATA SHEET

Endura AZ20 oxygen monitor

Combustion gas analysis



Measurement made easy

Superior technology and quality from the world leader in oxygen measurement

Advanced design and precision manufacturing

- Robust, long-life probe for process temperatures up to 800 °C (1472 °F)
- Proven cell design from over 50 years experience
- Fast response to process variations
- Stable and accurate oxygen measurement

Unique integrated auto-calibration system

- Easy compliance for emission monitoring regulation
- Reduced installation costs; eliminates requirement for expensive external calibration panel
- Reduced maintenance costs

Probe lengths up to 4.0 m (13.1 ft) and industry-standard

flange configurations

- Suitable for a wide range of applications
- Extensive installation options

Easy cell release

- Fully site-serviceable probe
- Easy access to internal components

Advanced transmitters

- Easy configuration, monitoring and intuitive HMI
- HART communications
- Cell performance logging and diagnostics

Introduction

The Endura AZ20 is the latest in a long line of high-quality, combustion gas analyzers from ABB.

The sensor, based on a zirconium oxide cell, is mounted at the tip of the probe that is inserted in the flue duct. The resulting direct, in situ measurement provides accurate and rapid oxygen reading for combustion control optimization and emissions monitoring.

Advanced design

Designed and manufactured to exacting standards, the Endura AZ20 ensures long periods of trouble-free operation in even the most arduous of applications.

The operating process temperature of up to 800 °C (1472 °F) extends system suitability into previously impossible applications and enables optimum probe location within the process.

The modular design, with reduced component count, improves the robustness and reliability of the system and simplifies routine maintenance and servicing.

Complete traceability ensures only the highest quality materials are used in the analyzer's construction and rigorous manufacturing, inspection and testing procedures (to international standard ISO 9001) result in a monitor of superior quality with prolonged probe life.



Modular construction

Probe lengths up to 4.0 m (13.1 ft)

A wide range of probe insertion lengths from 0.5 to 4.0 m (1.7 to 13.1 ft) enable installation to the optimum measuring point for accurate oxygen measurement within the duct; even in the largest flue gas ducts and stacks.

A comprehensive range of mounting flanges provide simple installation when plant-wide standard flanges are required or when replacing existing probes.

The transmitter can be probe- or remote-mounted at distances of up to 100 m (328 ft), thus providing versatile system options for all applications. The probe-mounted transmitter option provides the lowest cost of installation. However, the remote-mounted transmitter provides flexibility when the operationally ideal probe location does not provide easy access for the user.



Stainless steel remote transmitter

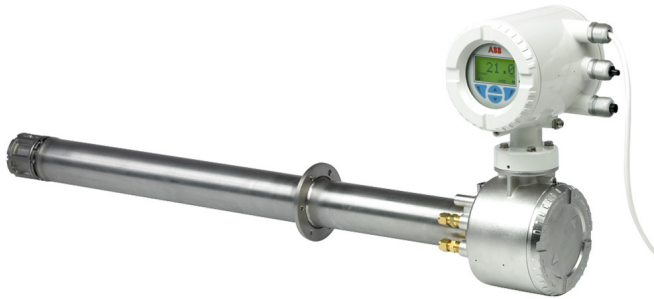

Probe and probe-mounted transmitter



Probe and remote-mounted transmitter

Easy cell release

The Endura AZ20 probe has retained the easy-access cell arrangement of the previous generation ZFG2 probes. Cell replacement can be performed on-site using basic hand tools; even after long periods of high temperature operation where screw threads have 'seized' and can no longer be released.

Kits containing all the parts needed to complete maintenance are available from ABB to ensure a technician can perform services quickly, efficiently and at minimum cost.

Proven cell design

ABB's metallurgically bonded, multi-layer electrode technology increases the cell's resistance to sulphurous and reducing atmospheres and high temperature operation. This extends the life-cycle of the cell in the most arduous applications such as sulphur recovery processes, crematoria and industrial/clinical waste incineration.



Zirconia cell

Optional flow rate control to the sensor

The correct flow rate of test gas and reference air is essential to ensure the accurate operation of Zirconia-based AZ20 oxygen analyzers.

This is achieved using one of two options:

- using flow restrictors (no flowmeters required):
 - flow restrictors fitted in the sensor head guarantee the correct flow of test gases and reference air by applying the gases/air to the probe at a fixed pressure of 15 psi (1.0 bar)
- using flowmeters (no restrictors):
 - the Endura AZ20 uses flow meters with flow control valves to regulate the flow of test gases and reference air into the sensor

Optional corrosion resistant coating

Used in applications where the process temperature is close to the sample acid dew point. This PFA coating protects the probe body against corrosion caused when acids condense out onto the probe. The exact temperature at which this occurs is dependent on the acid gas concentration and the water vapor content of the sample. This option is suitable where the process temperature is below 250 °C (482 °F)

Unique integrated automatic calibration

The all new Endura AZ20 automatic calibration system eliminates the need for the expensive ancillary equipment required for automatic calibration on traditional flue gas oxygen analyzer systems. ABB's fully integrated, automatic calibration feature controls the test gas sequence and detects test gas availability, eliminating incorrect calibrations due to loss of test gas.

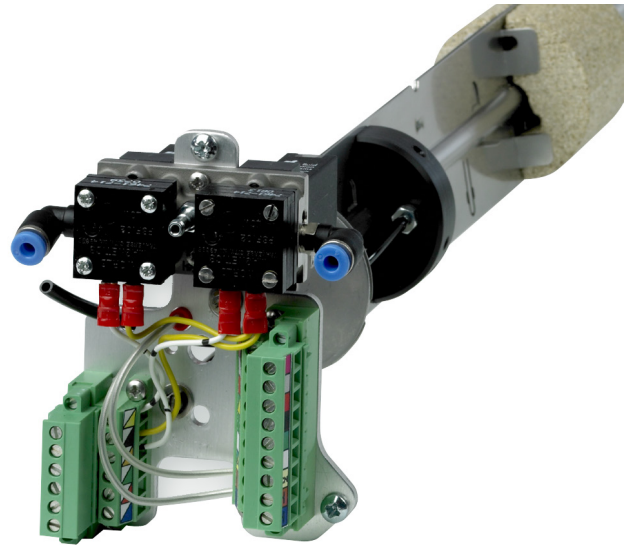

Advanced automatic calibration facility

Integrated automatic calibration secures the oxygen measurement, providing complete confidence in the analyzer's performance.

Long-term operation without technician intervention minimizes operating costs, total cost-of-ownership, optimizes system accuracy and contributes to the CEMS (Continuous Emissions Monitoring Compliance). A significant proportion of service visits to an analyzer result in 'no fault found'. Endura AZ20's high-quality manufacture, advanced diagnostics and fully-integrated, automatic calibration is targeted at reducing this wasted effort and cost.

The AutoCal option can be used with or without the flow restrictors option.

Filter options

An optional large surface area filter for high dust applications is available and can be easily retro-fitted if required..

Advanced transmitter

The Endura AZ20 transmitter incorporates the most up-to-date design and technology available today.

ABB's universal human/machine interface (HMI) with its large, clear, backlit graphical display, 'through-the-glass' control and intuitive menu structure simplifies transmitter configuration and operation.

The user-friendly interface enables fast, easy data entry for all parameters and the 'Easy Setup' menu speeds and simplifies system commissioning.

Advanced diagnostics, in accordance with NAMUR NE107, classify alarms and warnings as 'Maintenance Required', 'Check Function', 'Failure' and 'Out-of-Specification'. Cell performance is monitored by the transmitter; indicators such as cell impedance, rate-of-response to test gasses and changes in calibration offset/factor are recorded and analyzed. The current cell 'quality' is displayed by the transmitter as a visual indication of the measurement confidence; providing the operator all the information required to keep the monitor operating at peak performance.

The performance log holds up to 100 time-stamped events. When the log is full, the oldest data is overwritten by new entries. The log contains details of measurements and coefficients for all calibrations and accuracy checks.

2 relay outputs and a traditional analog output are fitted as standard, with the option of adding a second analog output or 2 digital inputs/outputs (I/O).

The Endura AZ20 transmitter is equipped with HART communication as standard, supported by a full Device Type Manager (DTM) to enable remote access to the analyzer through a user-friendly graphical interface. The DTM provides full access to the transmitter setup, logged data and diagnostics information as well as live data.

The IrDA standard infrared communication port can also be used with the DTM to upload and download device configurations. In addition, it enables data logged values and diagnostics to be viewed on a hyperterminal interface or a PC. The device's firmware can also be upgraded using this port.

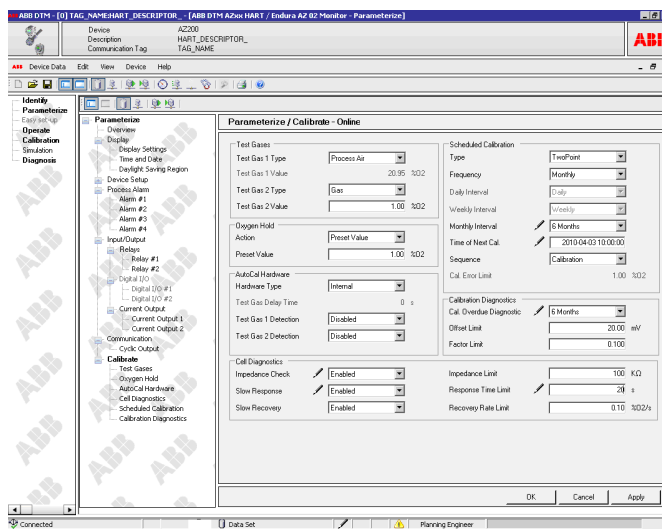

DTM graphical interface

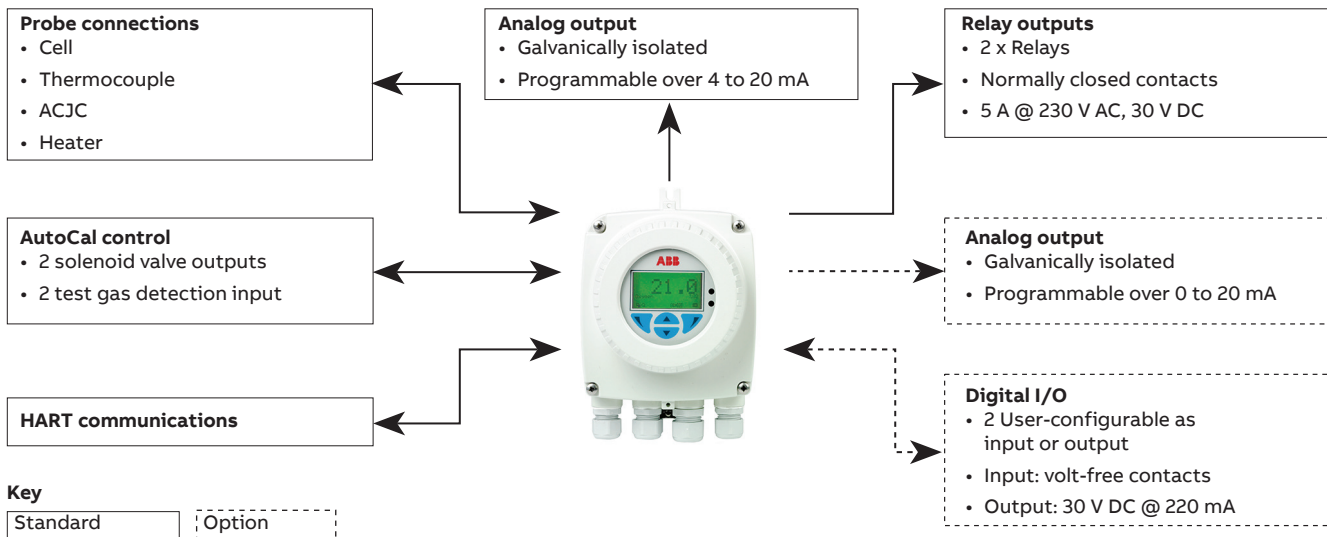

AZ20 system options

Probe with integral transmitter

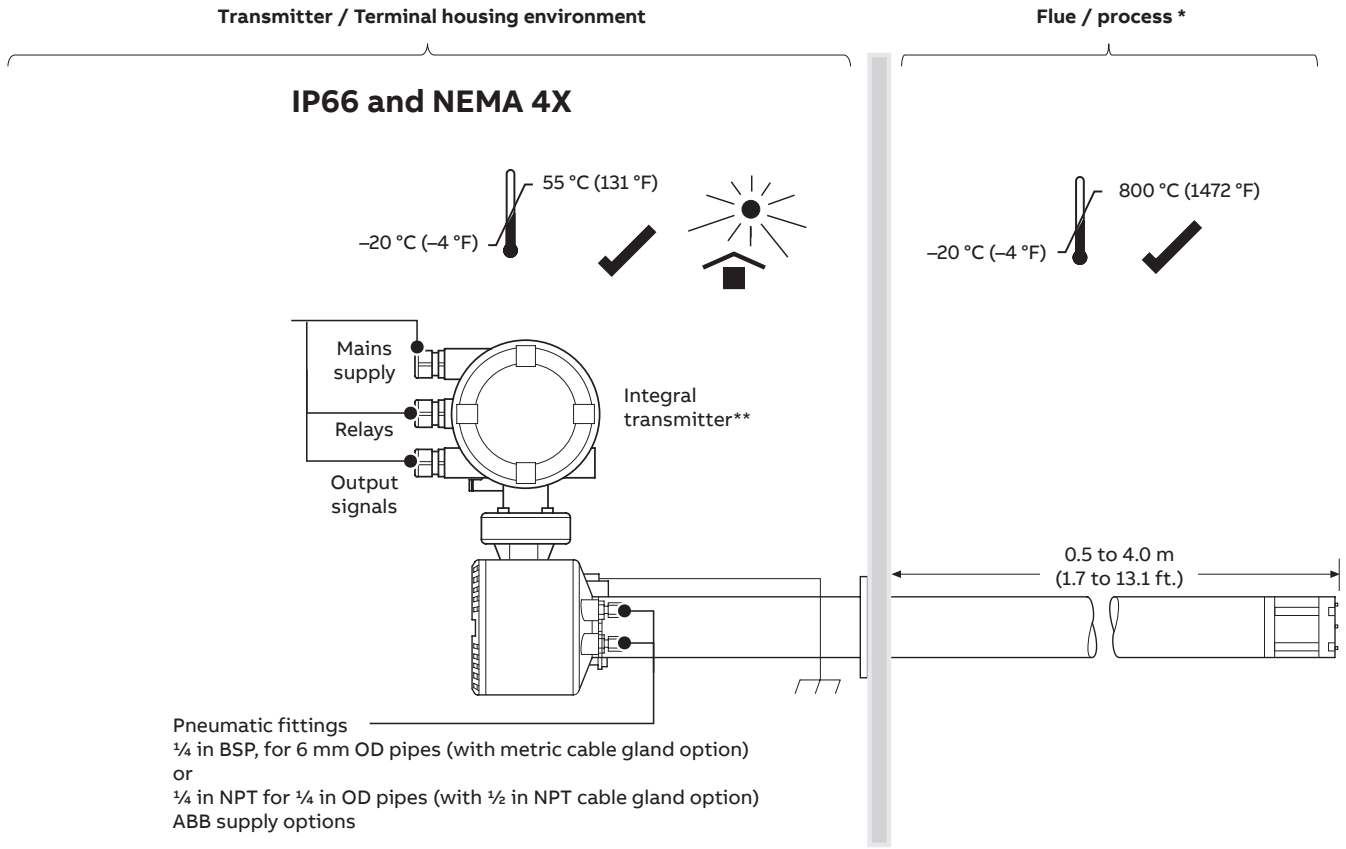

*Designed to withstand 35 kPa (5.1 psi) – positive or negative pressure.
 Pressure compensation required above 5 kPa (0.7) psi – transmitter can supply fixed pressure compensation
 **Transmitter does not contain a reference air supply for the probe.

Bypass system

This accessory enables standard AZ20 or AZ30 sensor systems to operate in high temperature environments of up to 1400 °C (2552 °F) without compromising their hazardous-area certification.

An air-powered ejector draws sample into the bypass system, passes it over the sensor and then returns it to the process.

Process flanges:

- DN80
- DN100
- ANSI 3 in
- ANSI 4 in

Ceramic inlet tube lengths:

- 600 mm
- 900 mm



...AZ20 system options

Probe with remote transmitter

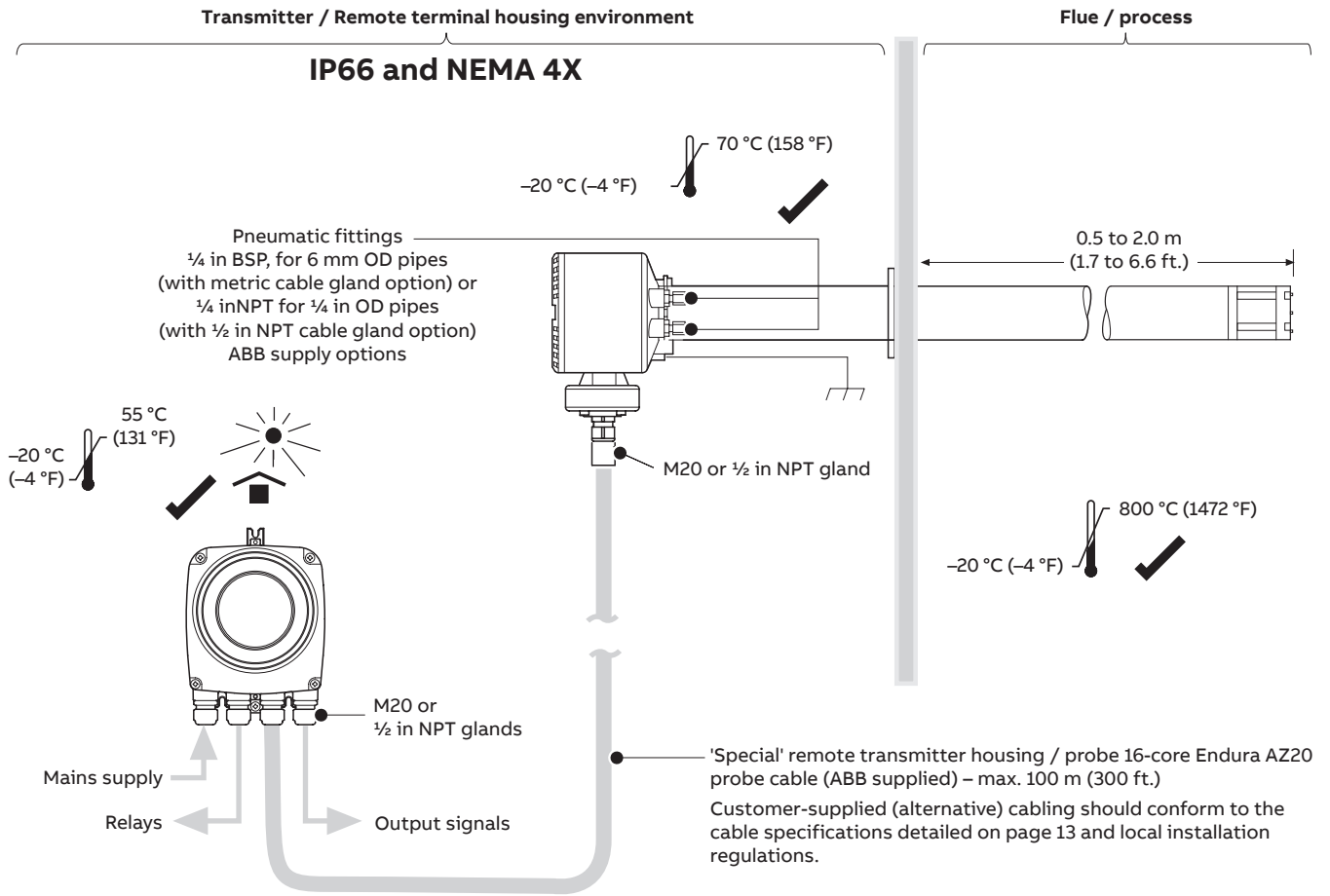

Probe with remote transmitter (stainless steel)/terminal housing

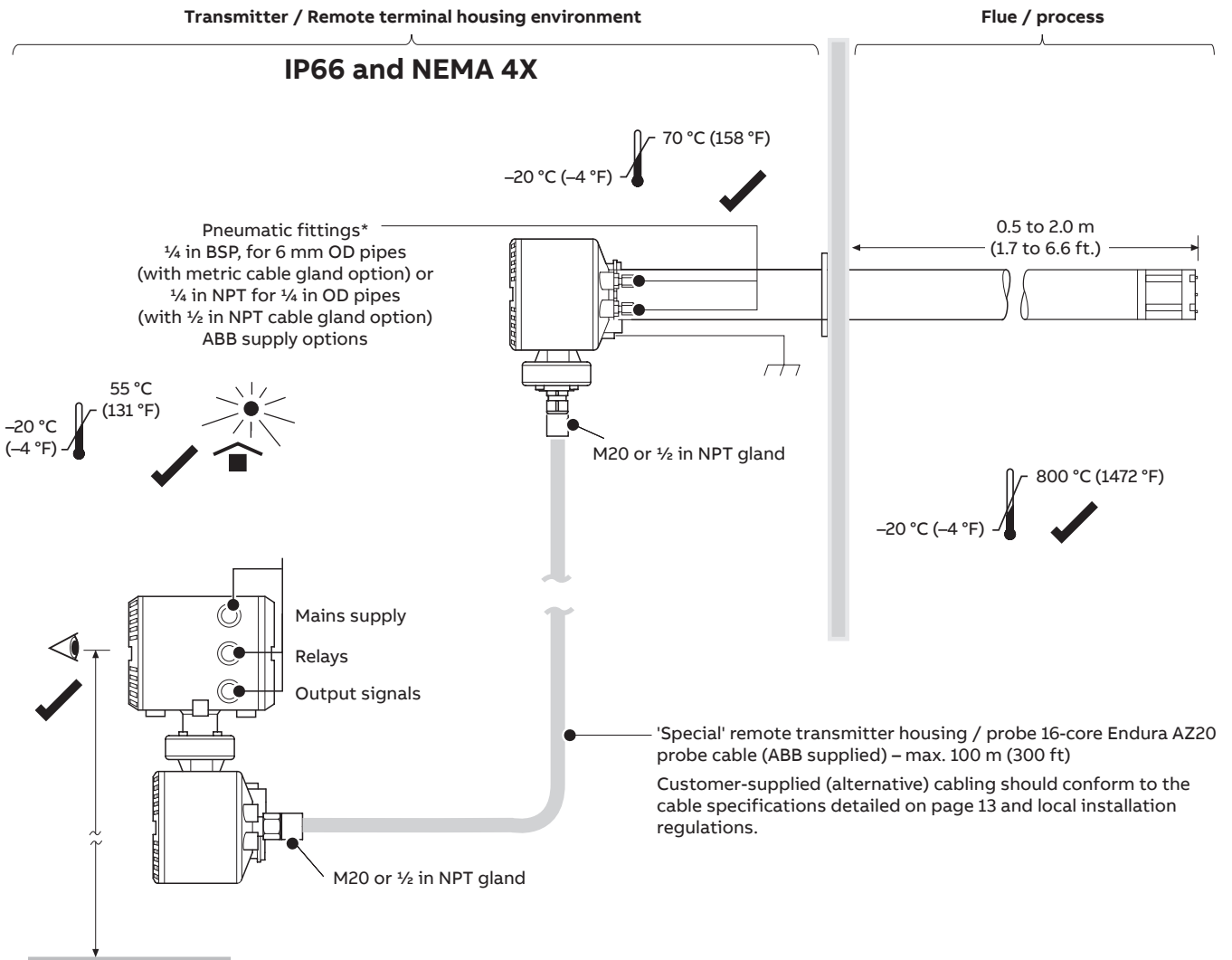

Test gas and reference air supply configurations

Automatic calibration (AutoCal) systems

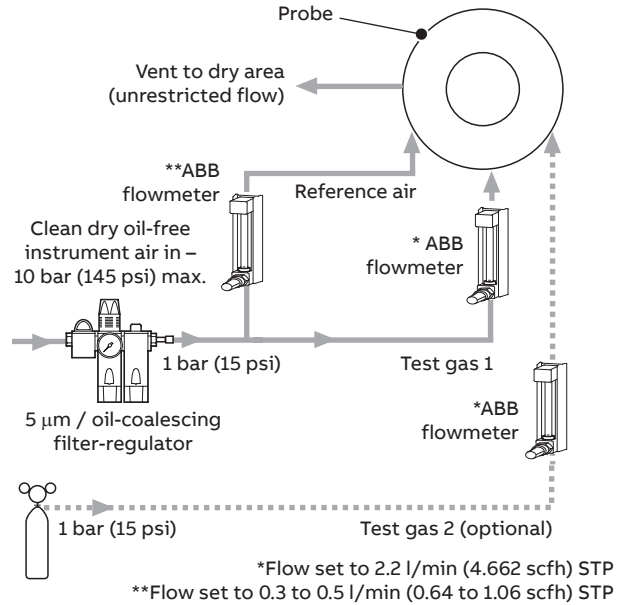
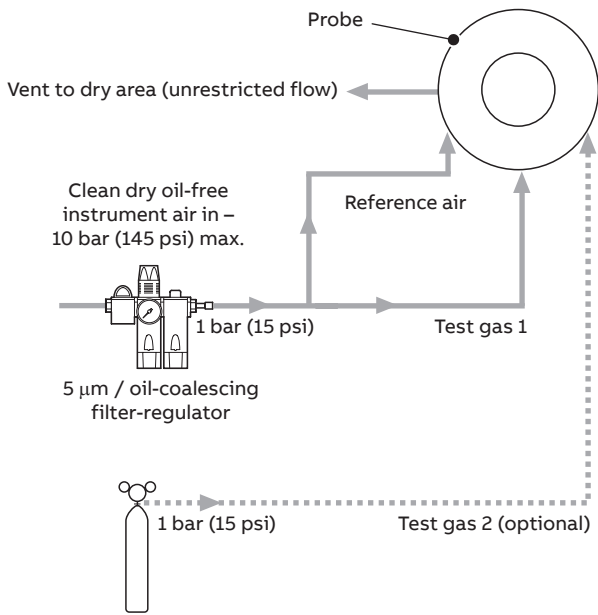

AutoCal with air supply and restrictors

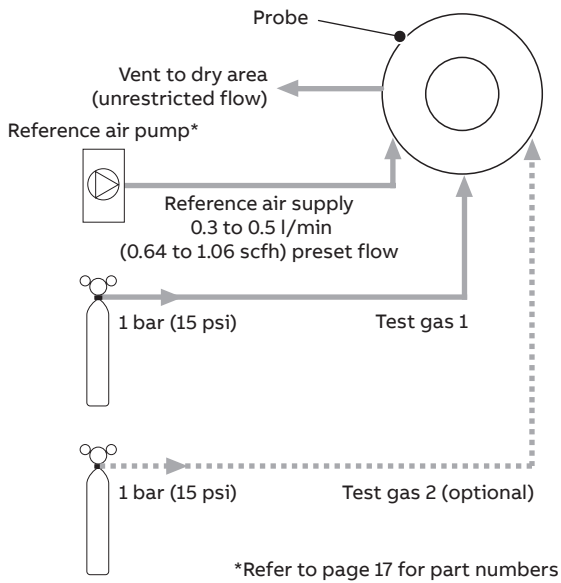

AutoCal with air supply and no restrictors

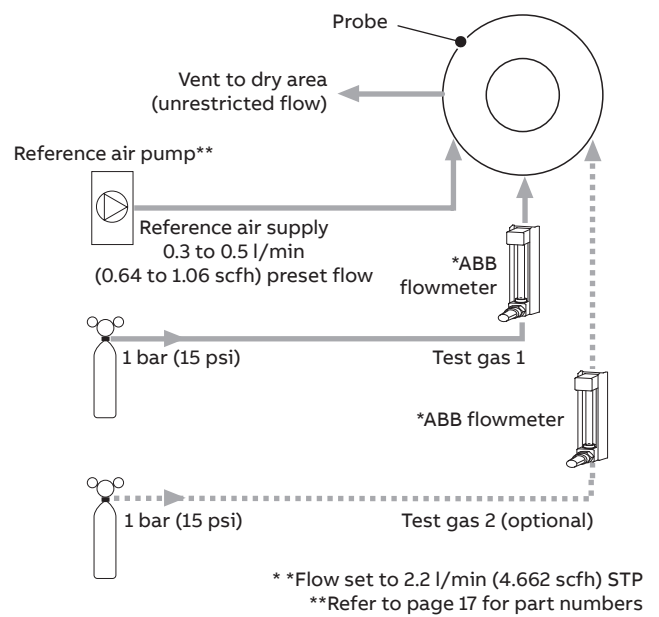

AutoCal with test gas(es) and restrictors

AutoCal with test gas(es) and no restrictors

Non-automatic calibration (non-AutoCal) systems

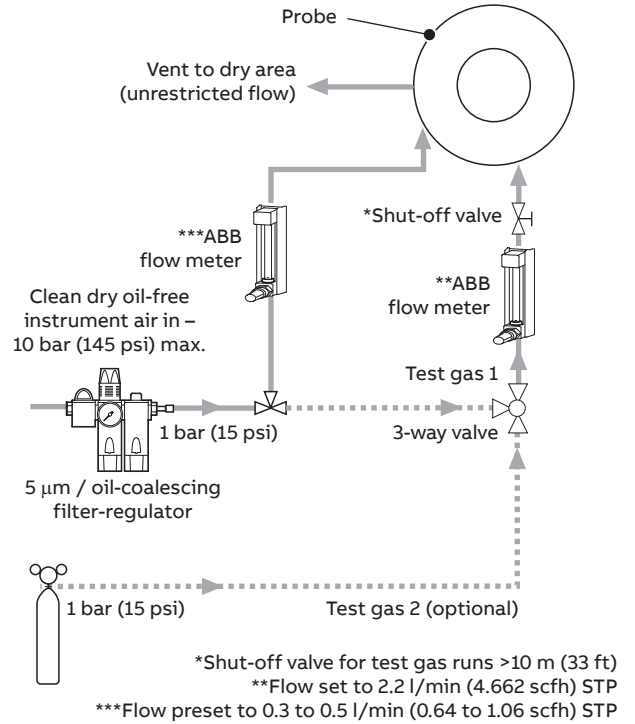
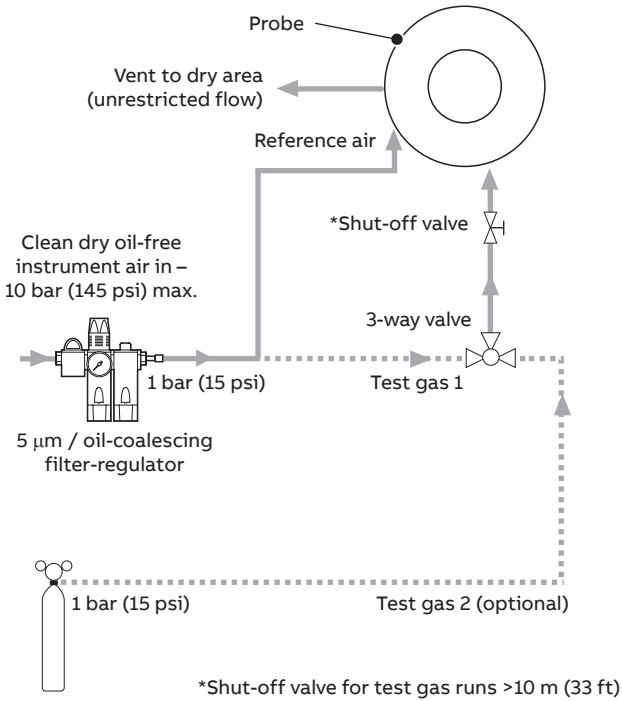

Non-AutoCal with air supply and restrictors

Non-AutoCal with air supply and no restrictors

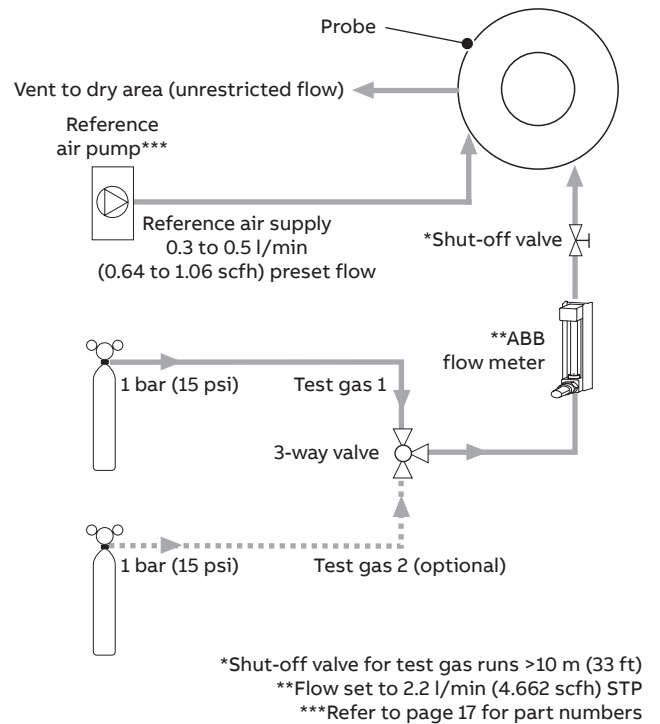
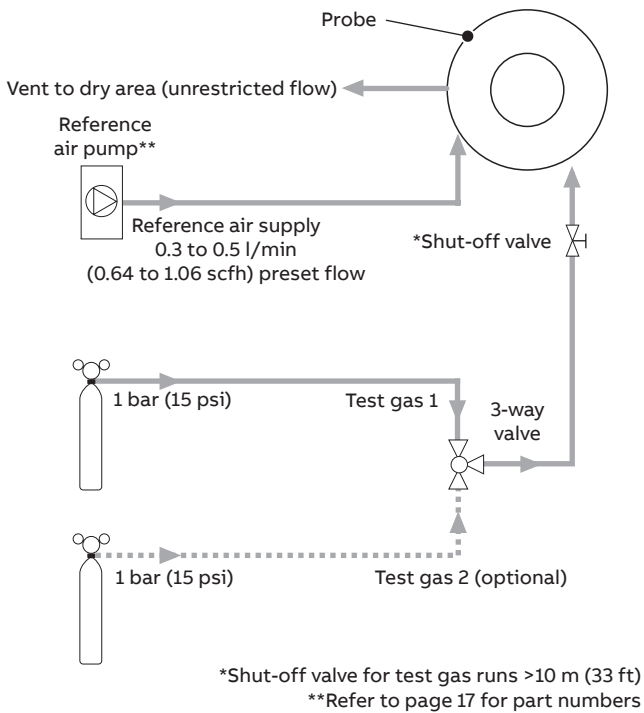

Non-AutoCal with test gas(es) and restrictors

Non-AutoCal with test gas(es) and no restrictors

Overall dimensions

Probe and integral transmitter

Dimensions in mm (in)

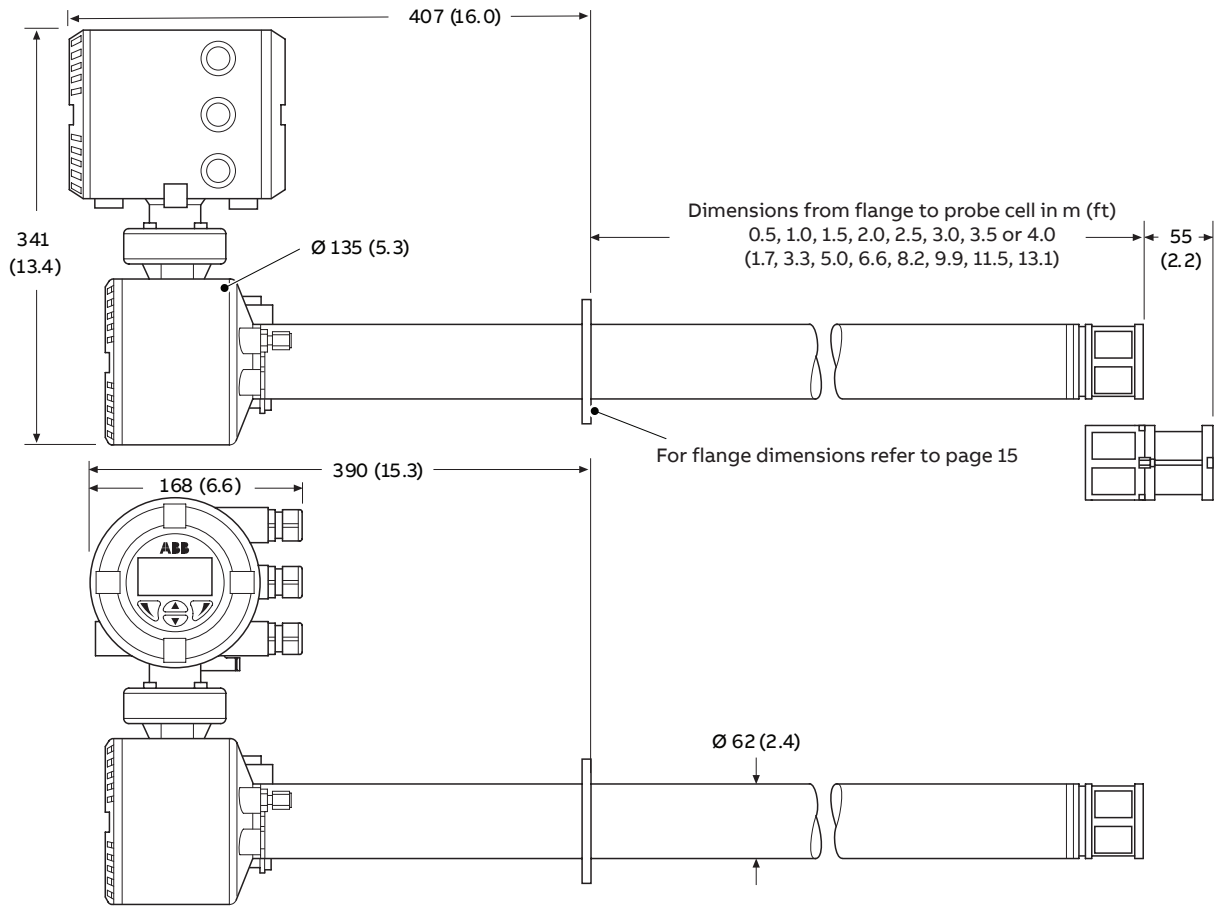

Probe and integral transmitter weights

Length m (ft)	Unpacked – kg (lb)	Packed – kg (lb)
0.5 (1.7)	12.5 (27.5)	17.72 (39.1)
1.0 (3.3)	14.8 (32.5)	21.43 (47.3)
1.5 (5.0)	17.0 (37.5)	25.14 (55.5)
2.0 (6.6)	19.3 (42.5)	28.35 (63.6)
2.5 (8.2)	21.5 (47.5)	34.17 (75.4)
3.0 (9.9)	23.8 (52.4)	37.38 (83.5)
3.5 (11.5)	26.0 (57.4)	41.59 (91.7)
4.0 (13.1)	28.3 (62.3)	45.30 (99.9)

Remote probe

Dimensions in mm (in)

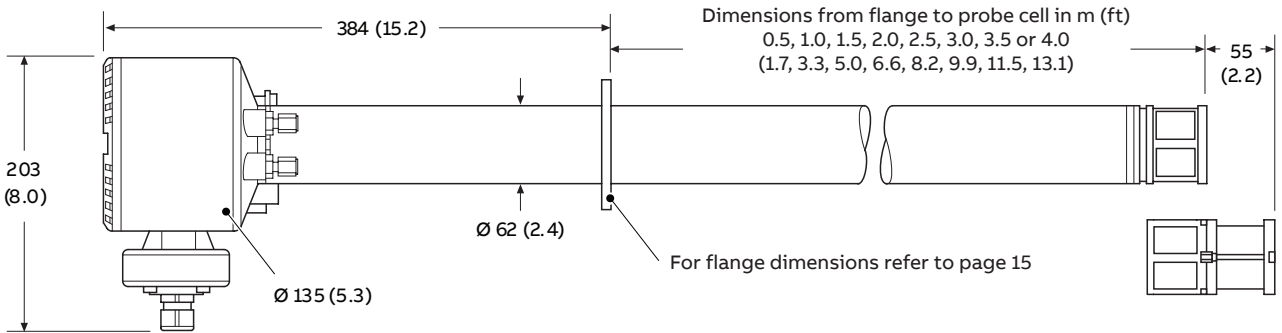

Remote probe weights

Length m (ft)	Probe only unpacked – kg (lb)	Probe only packed – kg (lb)	Probe and remote transmitter unpacked – kg (lb)	Probe and remote transmitter packed – kg (lb)
0.5 (1.7)	9 (19.9)	14.2 (31.4)	11.5 (25.4)	16.7 (36.9)
1.0 (3.3)	11.3 (24.9)	17.9 (39.6)	13.6 (30.3)	20.5 (45.1)
1.5 (5.0)	13.5 (29.8)	21.7 (47.7)	16.0 (35.3)	24.2 (53.3)
2.0 (6.6)	15.8 (34.8)	25.4 (55.9)	18.3 (40.3)	27.9 (61.4)
2.5 (8.2)	18 (39.7)	30.7 (67.7)	20.5 (42.2)	33.2 (73.2)
3.0 (9.9)	20.3 (44.7)	34.4 (75.8)	22.8 (50.2)	36.9 (81.3)
3.5 (11.5)	22.5 (49.6)	38.1 (84.0)	25.0 (55.2)	40.6 (89.5)
4.0 (13.1)	24.8 (54.6)	41.8 (92.2)	27.3 (60.1)	44.3 (97.7)

Remote transmitter

Dimensions in mm (in)

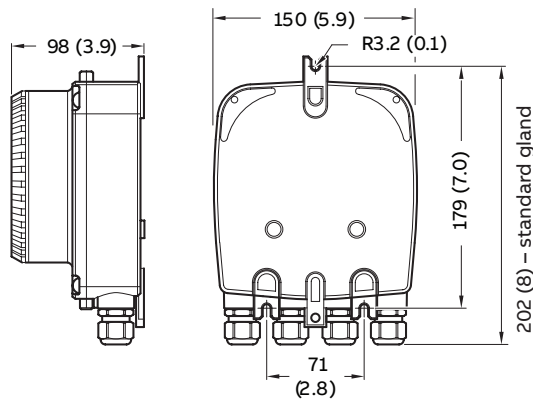

...Overall dimensions

Remote transmitter (stainless steel)

Dimensions in mm (in)

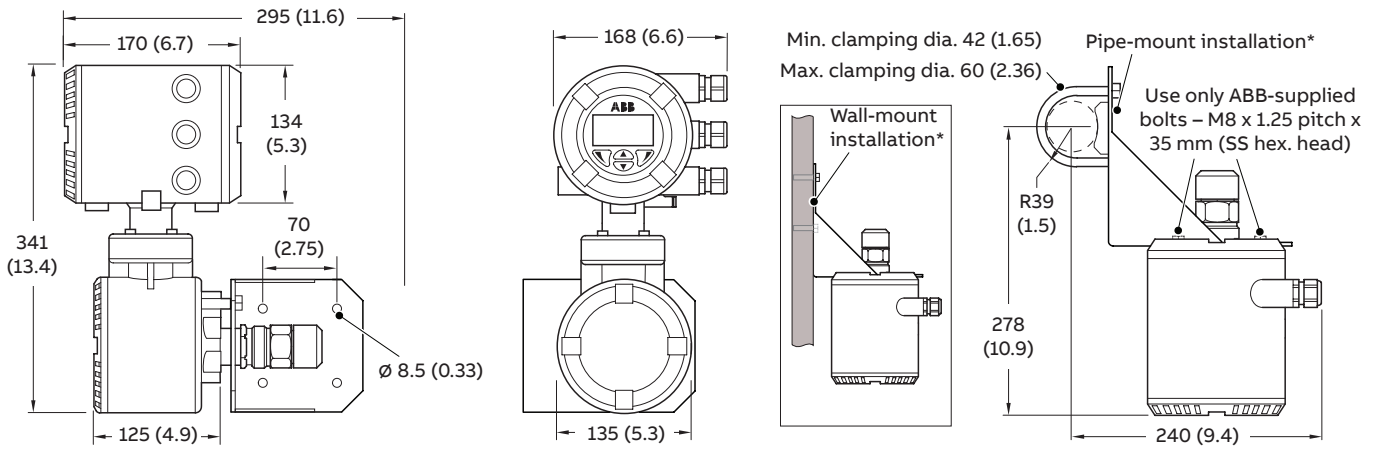

*Wall-/Pipe-mount bracket plus U-bolt, pipe clamp and M8 fixings supplied as standard

Remote transmitter weights

Remote transmitter unpacked – kg (lb)	Remote transmitter packed – kg (lb)
15.0 (30.07)	15.3 (33.73)

Probe flanges (all probe lengths) and mounting plates for standard probe flanges

Dimensions in mm (in).

Note. The pressure ratings for these flanges do not apply.

Flange type	A	B	C (Ø)	D (PCD)
ABB standard 0.5 m [1.7 ft.] probes only	101 (3.97)	6 (0.24)	7.3 (0.29)	80 (3.15)
ABB standard	165 (6.50)	12 (0.47)	12.5 (0.50)	140 (5.51)



ABB probe flange types, dimensions

Flange type	A	B	C	D
0.5 m (1.7 ft)	160 (6.3)	160 (6.3)	7 (0.27)	16 (0.63)
1.0 to 4.0 m (3.3 to 13.1 ft)	203 (8.0)	203 (8.0)	20 (0.79)	32 (1.26)

Comprising: mounting plate, gasket, 6 each: M6/M10 shakeproof washers, plain washers and nuts

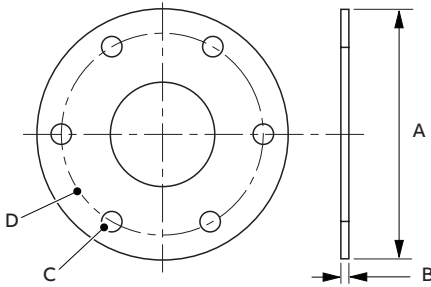
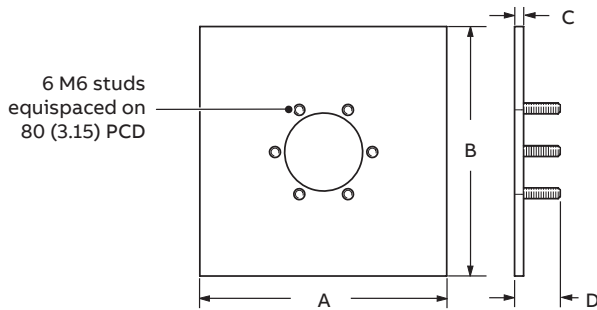

Standard mounting plate for 0.5 m (1.7 ft) probe – part no. AZ200 796

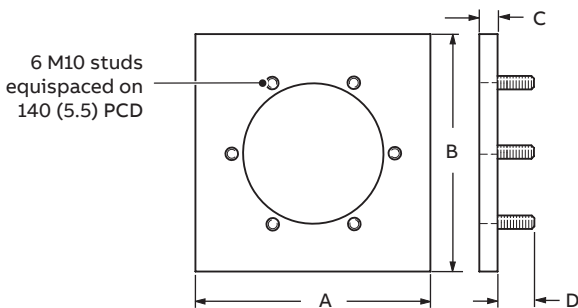

Standard mounting plate for 1.0 to 4 m (3.3 to 13.1 ft) probes – Part No. AZ200 795

ABB flange mounting plates

Flange type	A	B	C (Ø)	D (PCD)
ANSI 2 in 150	152.4 (6.00)	12 (0.47)	19 (0.75)	120.6 (4.75)
ANSI 2.5 in 150	177.8 (7.00)	12 (0.47)	19 (0.75)	139.7 (5.50)
ANSI 3 in 150	190.5 (7.50)	12 (0.47)	19 (0.75)	152.4 (6.00)
DIN 65 PN16	185 (7.28)	12 (0.47)	18 (0.70)	145 (5.70)
JIS 65 5K	155 (6.10)	12 (0.47)	15 (0.59)	130 (5.12)
JIS 80 5K	180 (7.08)	12 (0.47)	19 (0.75)	145 (5.71)

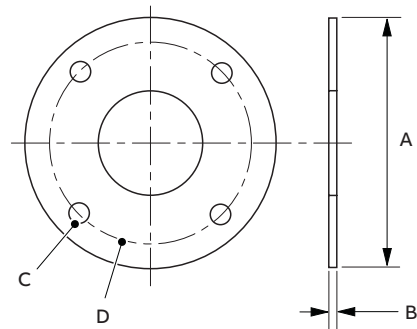

4-hole probe flange types and dimensions

Flange type	A	B	C (Ø)	D (PCD)
ANSI 4 in 150	228.6 (9.0)	12 (0.47)	19 (0.75)	190.5 (7.50)
DIN 80 PN16	200 (7.87)	12 (0.47)	18 (0.70)	160 (6.30)
DIN 100 PN16	220 (8.66)	12 (0.47)	18 (0.70)	180 (7.08)
JIS 100 5K	200 (7.87)	12 (0.47)	19 (0.75)	165 (6.50)

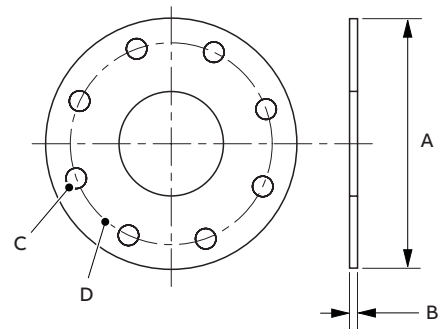

8-hole probe flange types and dimensions

Probe cable connections – remote transmitter (stainless steel) terminal housing to probe

Standard ABB cable specifications

Tx wire ident number	Terminal label color	(Position) Terminal block connection	Cable color	Cable requirement
Separately screened heater supply				
1	Blue	(1) Heater	Blue	0.75 mm ²
2	Brown	(2) Heater	Brown	0.75 mm ²
Heater screen/drain				0.5 mm ²
Separately screened signal cables				
Chassis earth				0.5 mm ²
	Yellow (SCN)	(3) Screen (twisted pair/sleeved)	Screens (Yellow/Green)	
4	White	(4) Thermocouple (negative)	White	0.5 mm ²
5	Green	(5) Thermocouple (positive)	Green	0.5 mm ²
6	Black	(6) Oxygen input (negative)	Black	0.5 mm ²
7	Red	(7) Oxygen input (positive)	Red	0.5 mm ²
8	Grey	(8) PT1000 Cold Junction Compensation	Grey	0.5 mm ²
9	Violet	(9) PT1000 Cold Junction Compensation	Violet	0.5 mm ²
10	White/Yellow	(10) Pressure Switch(1) Gas 2	White/Yellow	0.5 mm ²
11	White /Black	(11) Pressure Switch/Common	White/Black	0.5 mm ²
12	White/Orange	(12) Pressure Switch/Gas 1	White/Orange	0.5 mm ²
13	White/Green	(13) Solenoid Valve/Gas 1	White/Green	0.5 mm ²
14	White/Red	(14) Solenoid Valve/Common	White/Red	0.5 mm ²
15	White/Blue	(15) Solenoid Valve/Gas 2	White/Blue	0.5 mm ²
Signal cables screen/drain				0.5 mm ²

Requirements for non-ABB supplied cable/conduit

Screens and drains:

- Heater wires must be sleeved separately from the screened signal cables.

Heater cores (items 1 and 2) and heater drain

- Heater cores: 0.75 mm², 24/0.2 Cu wire, resistance (20C) 26 Ω/km max.
- Heater drain: 0.5 mm², 16/0.2 Cu wire, resistance (20C) 39 Ω/km max.

Signal cores (items 3, 15) and signal drain

- Signal cores/signal drain: 0.5 mm², 16/0.2 Cu wire, resistance (20C) 39 Ω/Km max.

Voltage rating

- 300 V to earth.
- 500 V between cores.

Cable (non-ABB supply) operating temperature requirements

- -20 °C (-4 °F) min.; 80 °C (176 °F) max.

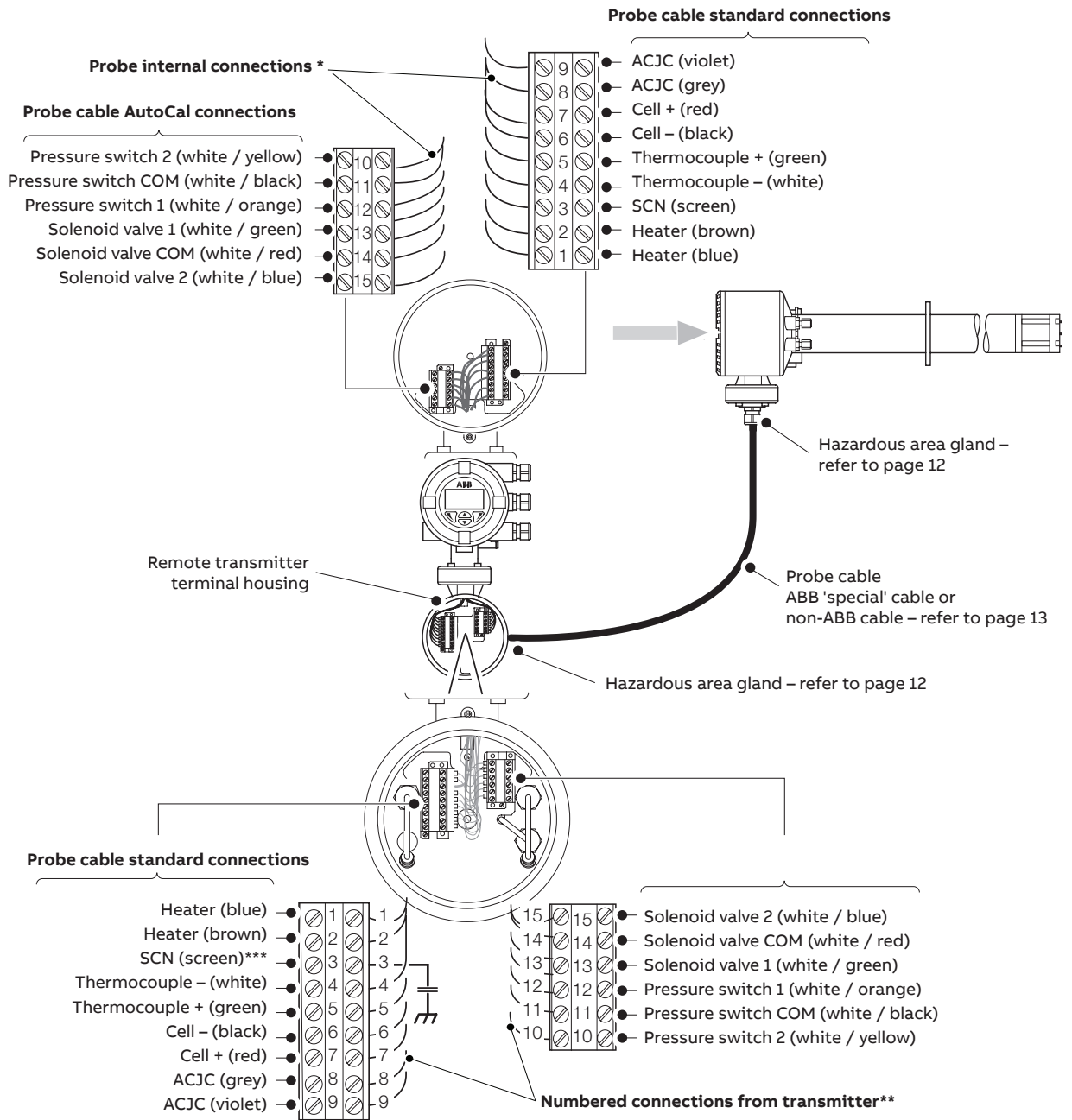

*Probe internal connections already made at the factory.

**Numbered connections from the transmitter to the transmitter's terminal housing already made at the factory.

***Screens must be connected to terminal 3 in the remote terminal housing where they are earthed via a de-coupling capacitor. Screens must not be connected directly to earth elsewhere.

...Probe cable connections – remote transmitter terminal housing to probe

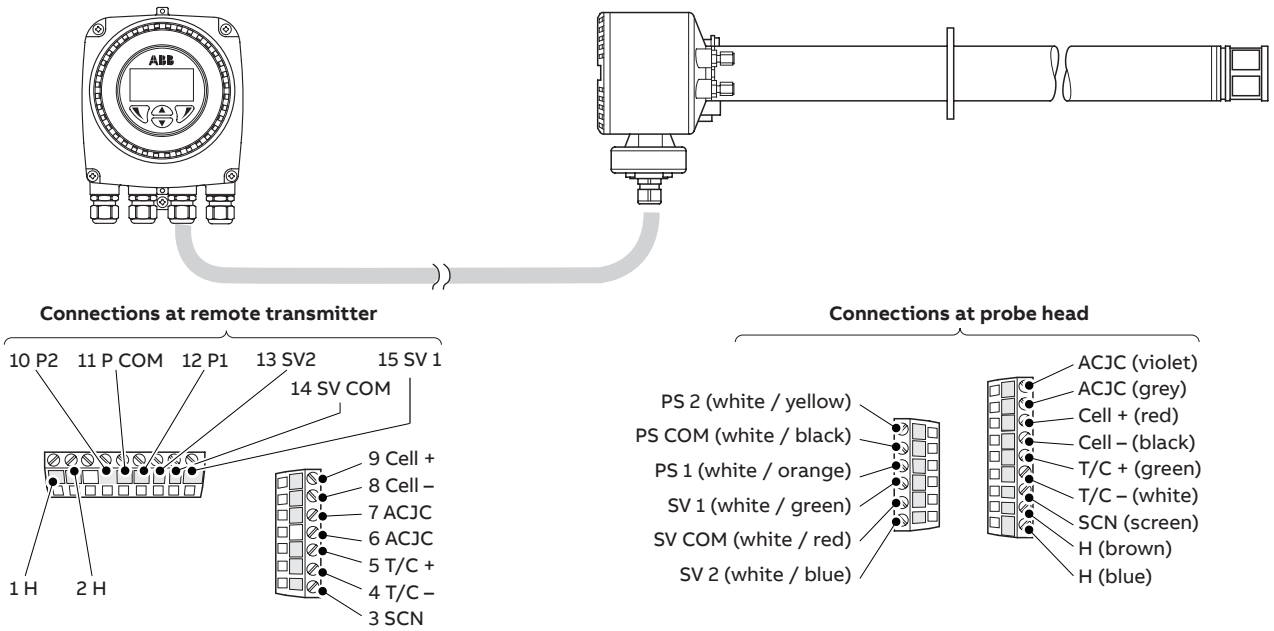

Electrical connections – remote transmitter and probe

Integral and remote (stainless steel) transmitter – power supply and output connections

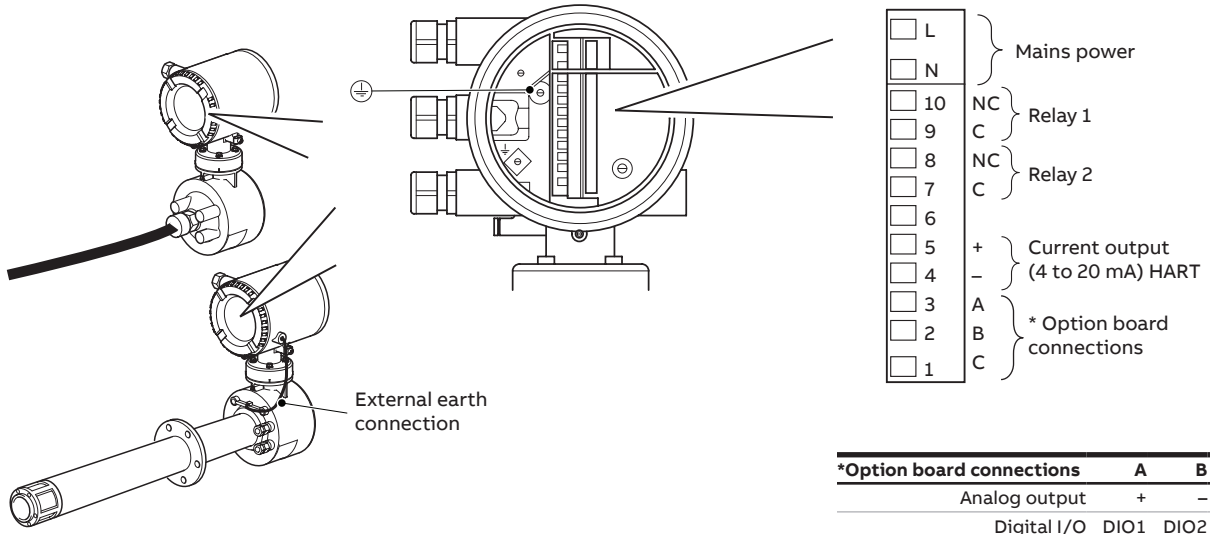

Integral transmitter – power supply and output connections

Remote transmitter – power supply and output connections

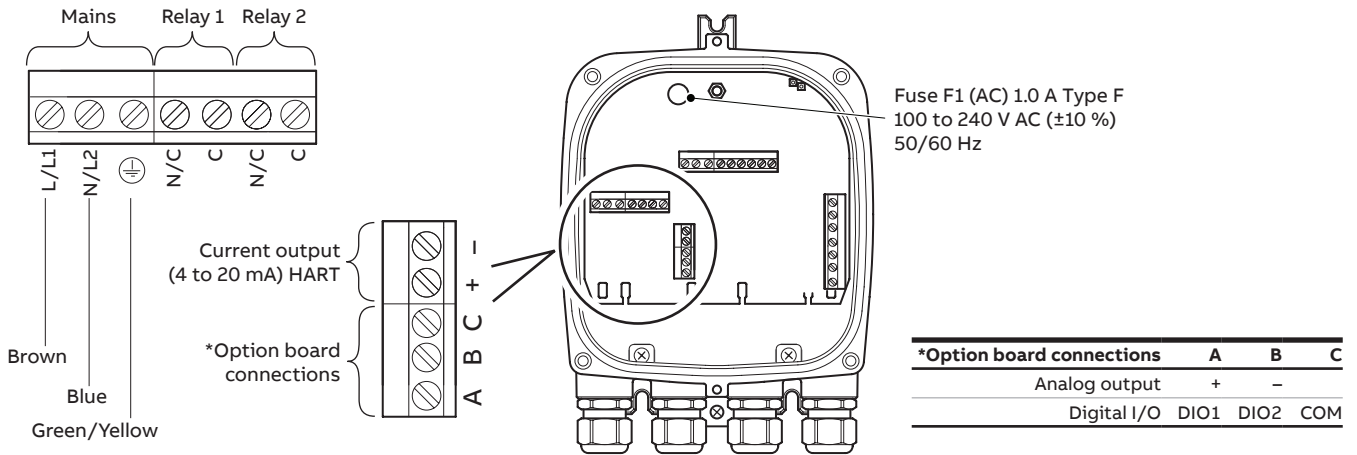

Remote transmitter – power supply and output connections

System specification

Measurement performance

Range:

0.01 to 100 % O₂

Test gas response time

- Initial dead time 3 seconds
- T₉₀ < 10 seconds

System accuracy

< ±0.75 % of reading or 0.05 % O₂, whichever is the greater, based on a nominal range of 0.01 to 25 % O₂ or 20 to 100 % O₂

Drift

- < ± 1 % maximum % O₂ range value per month (without calibration)
- < ± 0.2 % typical

Environmental data

Ambient operating temperature

- Transmitter -20 to 55 °C (-4 to 131 °F)
- Probe -20 to 70 °C (-4 to 158 °F)

Storage temperature

-40 to 85 °C (-40 to 185 °F)

Operating humidity

Up to 95 % RH, non-condensing

Sunlight

Store and operate out of direct sunlight

Ingress protection

- Probe (excludes remote/integral transmitter): IP66 (NEMA 4X)
- Electronics enclosures – remote and integral: IP66 (NEMA 4X)

Power supply

AC power supply

100 to 240 V AC ±10 % (90 V min. to 264 V max.) 50/60 Hz

Electronics

< 10 W

Probe heater

< 100 W

Approvals

- FM for USA and Canada
- CE marked
- EAC (Russia)
- MCERTS (QAL 1)
- TUV (QAL 1)
- Metrology (Russia)

Emissions immunity

Conforms to EN61326-1

General safety

Conforms to EN61010-1

Performance

Conforms to EN15267-3

Probe specification

Physical

Probe insertion lengths

- 0.5 m (1.7 ft)
- 1.0 m (3.3 ft)
- 1.5 m (5.0 ft)
- 2.0 m (6.6 ft)
- 2.5 m (8.2 ft)
- 3.0 m (9.9 ft)
- 3.5 m (11.5 ft)
- 4.0 m (13.1 ft)

Process connection

- All probe lengths
 - ANSI B16.5 150 lb
 - 2, 2.5, 3, 4 in
 - DIN2501 Part 1
 - 65, 80, 100 mm
 - JIS B2238 5K
 - NPT
 (flange pressure ratings do not apply)
- 0.5 m (1.7 ft) probes
ABB 500 mm (19.7 in) standard flange
- 1.0 m (3.3 ft) and longer
ABB 1000 mm (39.4 in) standard flange

Probe body material

316L stainless steel

Mounting angle

Horizontal to vertically down

Note. Horizontally-mounted probes greater than 2.0 m (6.6 ft) in length may need to be supported.

Process conditions

Standard process temperature

All probe lengths* –20 to 800 °C (–4 to 1472 °F)

Process pressure

Designed to withstand 35 kPa (5.1 psi) – positive or negative (pressure compensation required above 5 kPa (0.7 psi) – transmitter can apply fixed pressure compensation)

Operating requirements

Reference air

Regulated supply	Probes with restrictors	1 bar (15 psi), flowmeters not required
	Probes without restrictors	1 bar (15 psi) flowmeters required with flow set to 0.3 to 0.5 l/min (0.64 to 1.06 scfh)
Pumped supply	Probes with/without restrictors	Preset flow 0.3 to 0.5 l/min (0.64 to 1.06 scfh)

Test gas

User-selectable, 100 to 0.1 % O₂ balance N₂ and/or air (air is recommended as one of the test gases)

Probes with restrictors	1 bar (15 psi) – flowmeters not required as restrictors preset flow to 2.2 l/min (4.662 scfh)
Probes without restrictors	1 bar (15 psi) – flowmeters required, set to 2.2 l/min (4.662 scfh) flow

Calibration

Manual, semi-automatic or automatic (controlled by Endura AZ20 transmitter)

Automatic calibration

AutoCal hardware

- Optional built-in solenoid valves for control of test gas flow
- Built-in pressure switches to detect presence of test gases

Heater operational requirements

AZ20 Probe

Nominally 190 Ω, 70 W at 115 V AC – power is limited to 70 W max. by AZ20 transmitter over an 85 to 265 V AC range

AZ20/ZFG2 replacement probe

Nominally 25 Ω, 120 W at 55 V AC – for use only with a ZDT analyzer or ZMT transmitter

* For > 2 m (6.6 ft) probes, special conditions may apply

Transmitter specification

Transmitter enclosures

Remote

- Wall-, pipe- or stand-mounted
- 4 gland entries
- Optional ½ in NPT, M20

Integral

- Head-mounted
- 3 gland entries
- Optional ½ in NPT, M20

Automatic calibration

AutoCal hardware

- Isolated solenoid valve control as standard, 24 V @ 2 W per valve*
- Dedicated isolated digital inputs to monitor pressure switch contacts as standard – voltage-free, normally closed with gas present

Display and switches

Display type

Graphical 128 x 64 pixel LCD

Display backlight

Green LED

Operator switches

4 capacitive switches (operated through the front glass)

Relay outputs

Number

2 standard

Type

Normally closed, 5 A @ 230 V AC
or 30 V DC (non-inductive)

Functions

User-configurable – can be activated by one or more of the following signals:

- Process alarm 1, 2, 3, 4
- Calibration in progress
- Calibration failed
- Out of test gas 1, 2
- Test gas 1 valve control
- Test gas 2 valve control
- Failure diagnostic
- Out-of-specification diagnostic
- Maintenance required diagnostic
- Function check diagnostic

*For driving internal automatic calibration (AutoCal) probes or can be used to drive external calibration units on remote transmitters only.

Analog outputs

Standard

- 1 isolated current output
- Programmable to retransmit oxygen (linear or logarithmic) or temperature
- Programmable over 4 to 20 mA
- Over-range capability to indicate system failure programmable from 4 to 22 mA

Optional

- 1 isolated current output
- Programmable to retransmit oxygen (linear or logarithmic) or temperature
- Programmable over 0 to 20 mA
- Over-range capability to indicate system failure programmable from 0 to 22 mA

Digital inputs/outputs

Number

2 (optional)

Type

User-configurable as either input or output

Input

Volt-free contact

Output

- Transistor switch capable of sinking 220 mA
- Low output, < 2 V DC
- Switch voltage 30 V DC maximum

Isolation

Not isolated from each other or from other circuitry

Input functions

User-configurable for:

- Automatic calibration start
- Automatic calibration stop
- Automatic calibration start/stop

Functions

User-configurable – can be activated by one or more of the following signals:

- Process alarm 1, 2, 3, 4
- Calibration in progress
- Calibration failed
- Out of test gas 1
- Out of test gas 2
- Test gas 1 valve control
- Test gas 2 valve control
- Failure diagnostic
- Out-of-specification diagnostic
- Maintenance required diagnostic
- Function check diagnostic

...Transmitter specification

Hart communications

Version

5.7 as standard

Integration

- Device Type Manager (DTM) and Electronic Device Description (EDD)
- Provide online/offline device configuration, online monitoring of measurement values and diagnostic states

DTM

- FDT v1.2.1 compliant
- Works with FDT framework packages (for example, ABB Asset Vision Basic)

EDD

Compliant with suitable framework tools (for example, SDC 625 and Simatic PDM tools)

Infrared service port

Accessibility

Through front face

Type:

IrDA standard

Baud rate

Up to 115 K baud

Functions

- Firmware update
- Remote HMI
- Diagnostic log download
- Datalog output
- HART via IrDA

Languages

English

Calibration

Manual calibration

- 1 point (offset)
- 1 point (factor)
- 2 point (offset + factor)

Automatic calibration

- 1 point (offset)
- 2 point (offset + factor)

Calibration control

- Front panel controls
- Digital inputs
- HART commands
- User-defined schedule

Calibration scheduler

User-defined schedule enables automatic calibration frequency to be set from 1 day to 12 months

Part numbers for Endura AZ20 and AZ20/ZFG2 replacement heaters, thermocouple/electrode assemblies and ABB flowmeters

Probe length	Part number
0.5 m (1.7 ft)	AZ200 710
1.0 m (3.3 ft)	AZ200 711
1.5 m (5.0 ft)	AZ200 712
2.0 m (6.6 ft)	AZ200 713
2.5 m (8.2 ft)	AZ200 714
3.0 m (9.9 ft)	AZ200 715
3.5 m (11.5 ft)	AZ200 716
4.0 m (13.1 ft)	AZ200 717

Endura AZ20 – standard heater assembly

Probe length	Part number
0.5 m (1.7 ft)	AZ200 720
1.0 m (3.3 ft)	AZ200 721
1.5 m (5.0 ft)	AZ200 722
2.0 m (6.6 ft)	AZ200 723

Endura AZ20/ZFG2 replacement probe – heater assembly

Probe length	Part number
0.5 m (1.7 ft)	AZ200 701
1.0 m (3.3 ft)	AZ200 702
1.5 m (5.0 ft)	AZ200 703
2.0 m (6.6 ft)	AZ200 704
2.5 m (8.2 ft)	AZ200 705
3.0 m (9.9 ft)	AZ200 706
3.5 m (11.5 ft)	AZ200 707
4.0 m (13.1 ft)	AZ200 708

Thermocouple/Electrode assembly

Probe length	Part number
¼ NPT flowmeter (reference air): 0.1 to 0.85 l/min (0.21 to 1.8 scfh) STP	AZ200 786
¼ BSP flowmeter (reference air): 0.1 to 0.85 l/min (0.21 to 1.8 scfh) STP	AZ200 787
¼ NPT flowmeter (test gas): 0.6 to 4.4 l/min (1.27 to 9.32 scfh) STP	AZ200 788
¼ BSP flowmeter (test gas): 0.6 to 4.4 l/min (1.27 to 9.32 scfh) STP	AZ200 789

ABB Flowmeters NPT/BSP

Spares and accessories

Documentation and software

Part number	Description
MI/AZ30M-EN	Maintenance Guide
	Download* the guide from: www.ABB.com/analytical-instruments *Enter this address in your browser and then type IM/AZ20M-EN in the search box – the Maintenance Guide is the top link.
AZ20 DTM Software	Device Type Manager – contact ABB for details

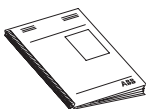

Probe spares

Part number	Description
Length dependant – see page 25 for part numbers	Thermocouple/electrode assembly
Length dependant – see page 25 for part numbers	AZ20 standard heater assembly AZ20/ZFG2 replacement heater assembly
AZ200 700	Cell assembly – includes C-ring and commissioning label
AZ200 727	Restrictor upgrade kit
AZ200 728	Probe end cap – includes wiring labels
AZ200 729	Diffuser assembly – includes C-ring
AZ200 730	AutoCal upgrade assembly
AZ200 737	Large surface area filter upgrade kit
AZ200 747	Large surface area filter spares kit
AZ200 746	Test gas injection pipe spares kit

Transmitter spares

Part number	Description
AZ200 750	AZ20 Transmitter cartridge
AZ200 751	• Standard
AZ200 752	• Standard + Analog O/P
AZ200 758	• Standard + Digital O/P
AZ200 758	Remote (type 4) Transmitter backplane
AZ200 757	Integral (type 3) Transmitter backplane

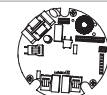
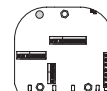

Accessories

Part number	Description
AZ200 731	Coalescing filter-regulator*
AZ200 732	• ¼ NPT 5 µm • ¼ BSP 5 µm *Required for reference and test gas air
AZ200 740	Filter elements for pre-June 2013 regulator:
AZ200 741	• 5µm filter element • Oil coalescing filter element
AZ200 742	Filter elements for post-June 2013 regulator
AZ200 743	• 5µm filter cartridge • Oil coalescing filter cartridge
AZ200 770	ABB reference air pump
AZ200 771	• ¼ BSP (metric) 230 V AC 50/60 Hz
AZ200 772	• ¼ BSP (metric) 115 V AC 50/60 Hz
AZ200 772	• ¼ NPT (imperial) 230 V AC 50/60 Hz
AZ200 773	• ¼ NPT (imperial) 115 V AC 50/60 Hz
AZ200 798	Probe tool kit*
AZ200 799	NPT (AZ20) BSP (AZ20) *Included with probe as standard
Application dependant – see page 25 for part numbers	ABB flowmeter
AZ200 785	USB to IrDA adaptor kit
AZ200 735	Filter dust shield
AZ200 736	Probe body erosion shield

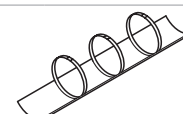
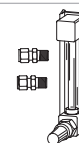
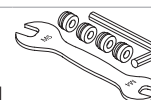
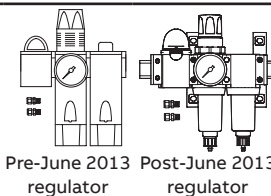

Ordering information

Endura AZ20 probe/transmitter

	AZ20/	Tx								Probe								STD
	X	X	X	X	X	X	X	X	X	X	X	X	X	X	0	X	X	
Transmitter options																		
None	0																	
Standard	1																	
Standard + 2 nd analog output	2																	
Standard + 2 digital inputs/outputs	3																	
Transmitter entry type																		
None (no transmitter required)	0																	
Metric (M20)	1																	
Imperial (NPT)	2																	
Transmitter system type																		
None (no transmitter required)																		0
Integral																		1
Remote																		2
Remote (stainless steel)																		3
Probe type																		
None (no probe required)																		0
Standard																		1
Probe entry type																		
None (no probe required)																		0
Metric (M20)																		1
Imperial (NPT)																		2
Probe system type																		
None (no probe required)																		0
Integral																		1
Remote																		2
Automatic calibration																		
None (no probe required)																		0
No automatic calibration (with flow restrictors)																		1
No automatic calibration (without flow restrictors)																		2
Automatic calibration (with flow restrictors)																		3
Automatic calibration (without flow restrictors)																		4
Insertion length																		
None (no probe required)																		0
0.5 m (1.7 ft)																		1
1.0 m (3.3 ft)																		2
1.5 m (5.0 ft)																		3
2.0 m (6.6 ft)																		4
2.5 m (8.2 ft)																		5
3.0 m (9.9 ft)																		6
3.5 m (11.5 ft)																		7
4.0 m (13.1 ft)																		8

Continued on next page...

Trademarks and acknowledgements

HART is a registered trademark of the HART Communication Foundation.

Sales



Service



Software



ABB Limited**Measurement & Analytics**

Oldends Lane

Stonehouse

Gloucestershire GL10 3TA

UK

Tel: +44 (0)1453 826 661

Fax: +44 (0)1453 829 671

Email: instrumentation@gb.abb.com**ABB Limited****Measurement & Analytics**

125 E. County Line Road

Warminster PA 18974

USA

Tel: +1 215 674 6000

Fax: +1 215 674 7183

abb.com/measurement

We reserve the right to make technical changes or modify the contents of this document without prior notice. With regard to purchase orders, the agreed particulars shall prevail.
ABB does not accept any responsibility whatsoever for potential errors or possible lack of information in this document.

We reserve all rights in this document and in the subject matter and illustrations contained therein. Any reproduction, disclosure to third parties or utilization of its contents – in whole or in parts – is forbidden without prior written consent of ABB.