

ABB MEASUREMENT & ANALYTICS | DATA SHEET | DS/700ULTRAD-EN REV. E

700 ULTRA-D

Digital pH/ORP sensor



Measurement made easy

The 12 mm digital pH/ORP sensor for use in ultrapure applications

Increased efficiency

- ABB's glass formulation provides fast process response without compromising durability and robustness
- Close-coupled temperature measurement ensures high accuracy even with rapid temperature changes

EZLink™ connectivity

- Plug-and-play technology makes sensor integration fast and easy
- Advanced diagnostics providing end-of-life indication and fault analysis
- Improved measurement accuracy with digital communication

Dependable performance

- Refillable KCl reservoir providing maximum usability and extended operation in high purity applications with minimal drift
- Triple ceramic junction reduces plugging while providing improved measurement stability and speed of response

Modular design

- Modular 12 mm sensor design, paired with intelligent accessories, provides mounting flexibility with safety and convenience in mind

Introduction

Making the right sensor selection for your application should be simple and easy. To help you make the right choice, we've divided our new family of pH/ORP sensors into three distinct ranges based on the applications they have been designed for; the 100, 500 and 700 ranges.

The 100 range are entry-level sensors designed for light duty use, while the 500 range offer a robust design for industrial applications. The 700 range are a specialty range for target applications.

Each electrode is clearly named and is also color-coded for ease of identification. This enables you to easily select the best sensor to meet your needs, ensuring optimal plant efficiency, performance and lifetime; every time.

The 700 ULTRA-D digital pH/ORP sensor

Part of the next generation of ABB's pH/ORP sensors, the digital 700 ULTRA-D is a high-performance electrode designed for ultra-pure water applications. Its reservoir-fed rechargeable design provides extended operation and minimal drift for applications down to 0.055 $\mu\text{S}/\text{cm}$.

The 700 ULTRA-D is designed for use in:

- boiler water
- demineralized water
- power plants
- steam water analysis
- reverse osmosis
- condensate/feedwater

Performance you can trust

Featuring a rechargeable reservoir-fed design, the 700 ULTRA is capable of extended operation in ultrapure applications down to 0.055 $\mu\text{S}/\text{cm}$, minimizing the frequency of sensor replacement due to loss of electrolyte. With an enhanced triple ceramic junction design, the 700 ULTRA has improved speed of response while maintaining measurement stability in the most demanding high purity applications.

Refillable KCl design provides extended operation down to 0.055 $\mu\text{S}/\text{cm}$ and ensures minimal drift due to KCl loss

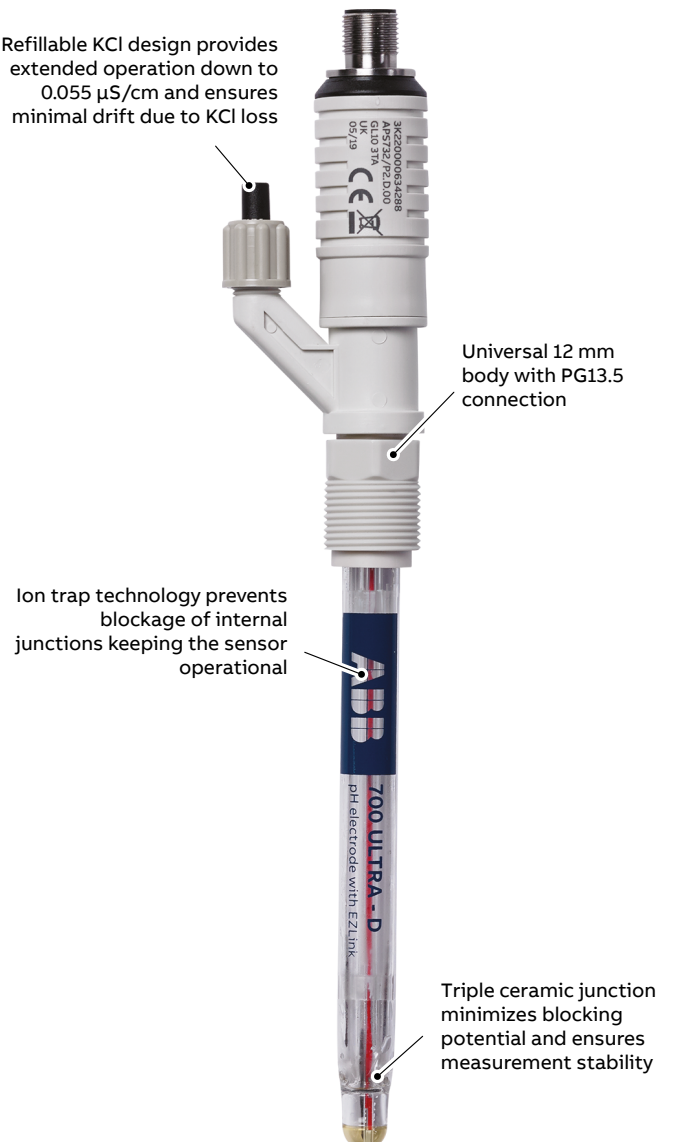

Improved process efficiency

Varying sample temperature is one of the most common causes of pH measurement error due to its impact on sensor output. The 700 ULTRA-D is equipped with a close-coupled temperature element capable of rapid response to quickly changing process conditions thus ensuring a high level of accuracy and confidence in your measurement.

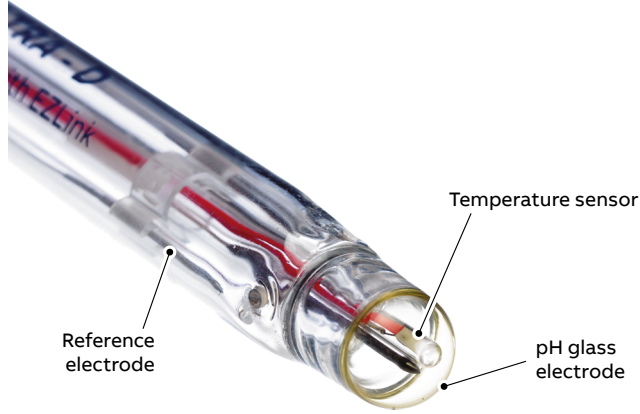

Temperature element location

EZLink connectivity

Convenient EZLink technology enables seamless plug-and-play integration when using the 700 ULTRA-D. Automatically recognized, the sensor uploads calibration, diagnostic and manufacturing information to any of ABB's EZLink-capable transmitters within seconds; significantly reducing commissioning and product maintenance.

Sensor health check

The 700 ULTRA-D provides advanced sensor diagnostics such as the unique perpetual impedance monitoring (patent-pending) that detects electrode faults such as **Broken Glass** or **Out-of-Sample** in real-time without the need for a solution earth.

In addition, ABB's SMART reference electrode monitoring (REM) system provides early warning notification of electrolyte loss enabling the sensor to be replenished when required, saving money without risking process control.

Enhanced accuracy

Instantaneous signal conditioning from analog to digital ensures minimal electrical interference and strengthens signal strength, greatly improving measurement accuracy even with longer cable distances.

EZLink plug-and-play connection simplifies user set-up with automatic sensor recognition and guidance

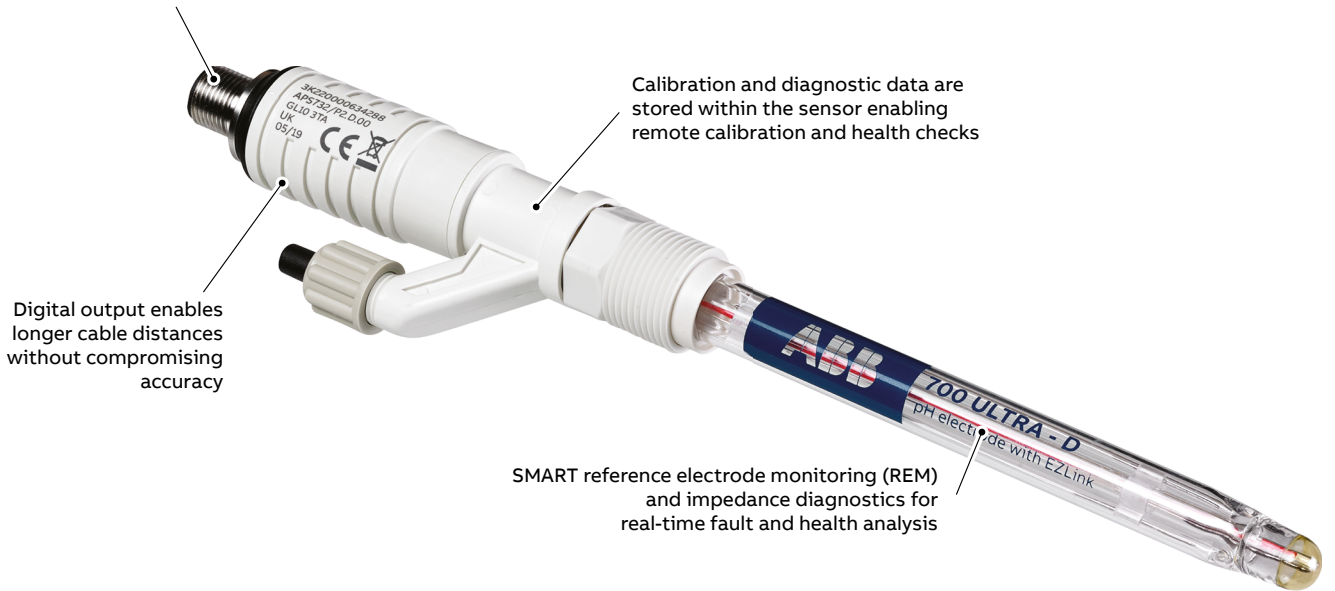

Key features

Robust glassware

Utilizing ABB's experience in glass manufacturing dating back to the 1950s, the proprietary glass formulations used with the 700 ULTRA-D offer fast response without sacrificing durability. Selectable in several configurations, the robust glassware is made suitable for wide range of general-purpose applications.

Low temperature (LT) glass

For measurement below 15 °C (59 °F), our low temperature blue glass provides ultrafast response in applications such as municipal and industrial wastewater treatment. Available in bullet style.

High-performance (S) glass

Our high-performance yellow glass provides fast response and accurate measurement over the entire pH range. With an extremely low sodium error, the glass can maintain its accuracy even at very high pH levels. Available in flat or bullet style.

ORP platinum electrode

Chemically inert, our platinum electrode is design for conventional ORP/Redox measurement with an RTD element providing process temperature information.



Low temperature glass



High-performance glass

Extended storage

We understand most customers maintain stock of pH/ORP sensors in case of unexpected demand. Ensuring peak performance, even after extended storage, is critical in maintaining product availability and keeping your process running.

The 700 ULTRA-D is stored in a specially formulated solution with added antimicrobial agent keeping the sensor active for up to 2 years when stored as recommended.



700 ULTRA panel

While some of our customers prefer to integrate their ABB products themselves, ABB has developed a range of easy and ready-to-install systems using industry-standard components and best practice in fitting design. Our panel-mounted analyzers include:

- standard sized backboard for wall-or rail mounting
- 700 ULTRA, flow-chambers and pipework
- predrilled panel and transmitter mounting holes
- isolation and flow control valves with indicators
- pH sensor calibration pot and bracket for easy calibration



Optional sampling panel

The 700 ULTRA panel offers a ready-to-install kit making commissioning quick and easy. Additional mounting accessories designed to improve adaptability are available for the 700ULTRA sensor and offer safe and convenient operation. The additional accessories include:

- flowcell
- quick-connect bayonet

Dimensions

Dimensions in mm (in)

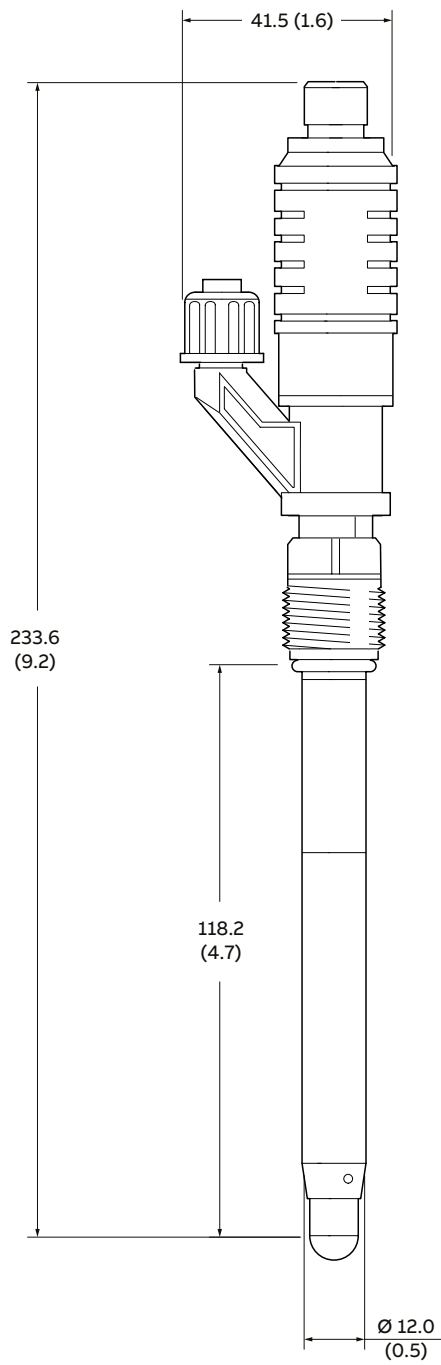

Sampling panel

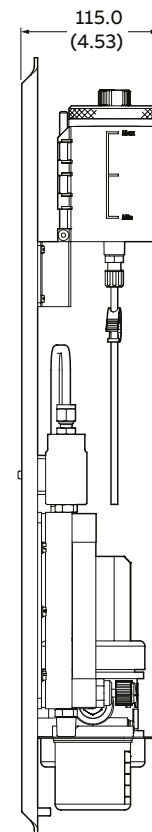
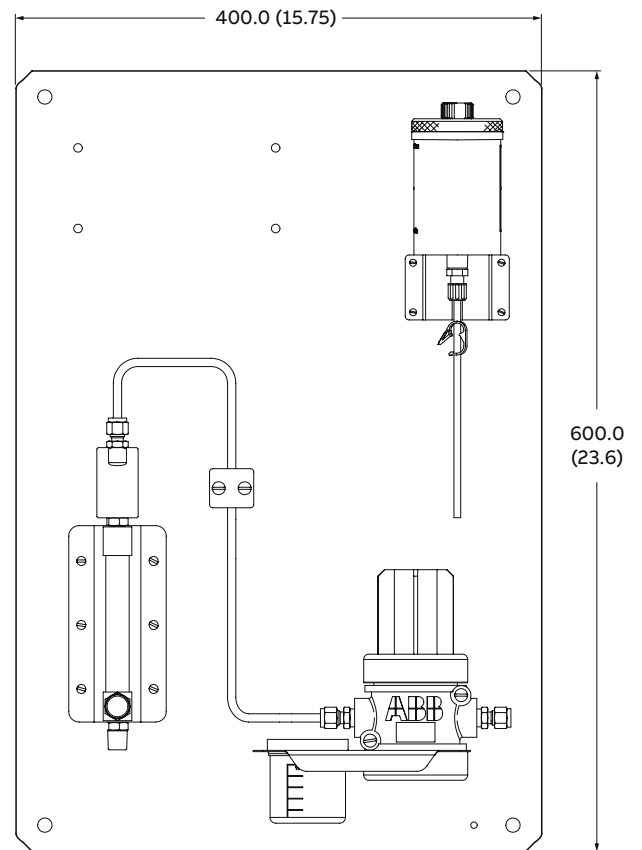

...Dimensions

Reservoir/flowcell assembly

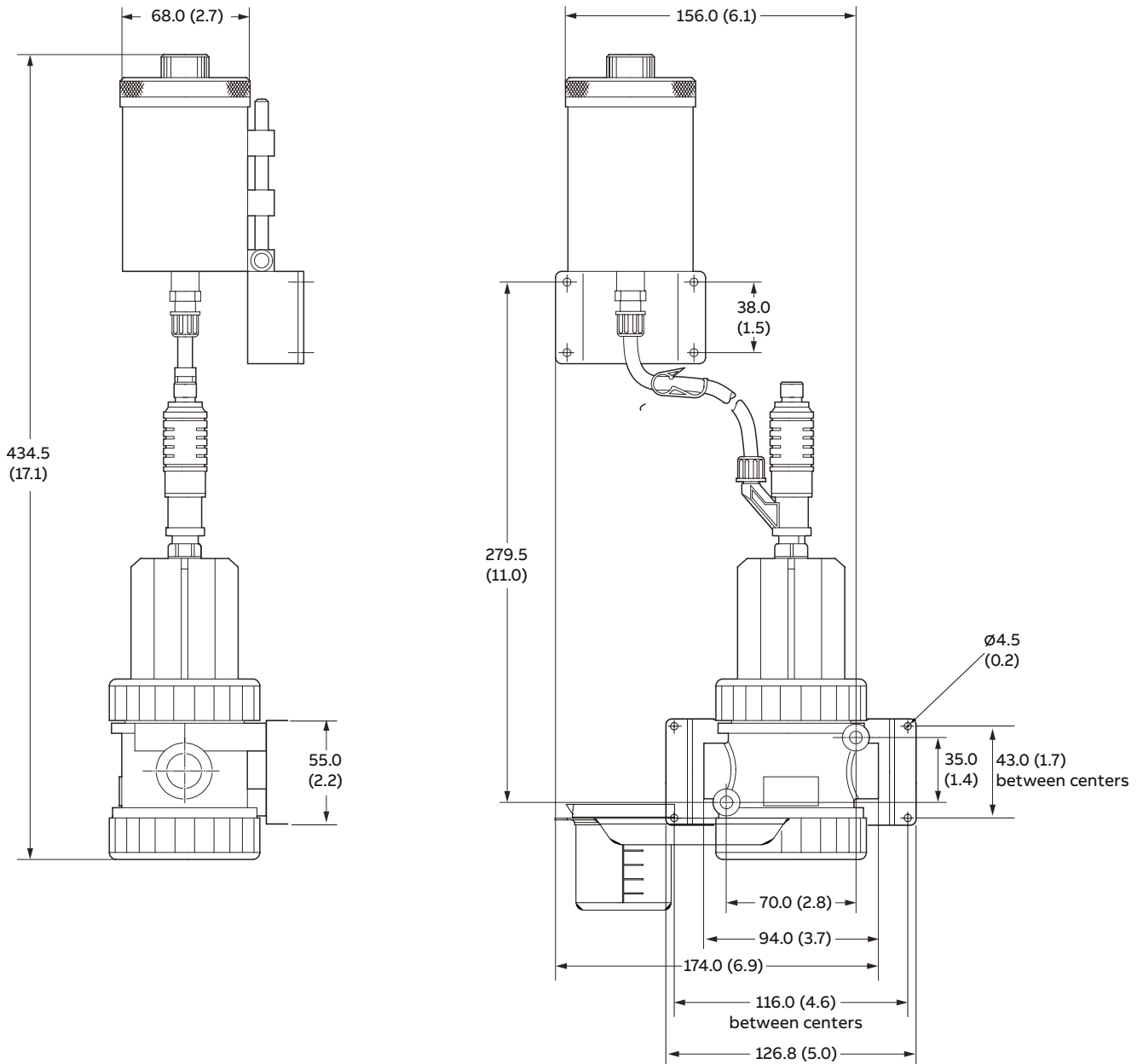

Electrical connections

All digital sensors are supplied with EZLink connectivity.

Specifications

Measurements

- pH/ORP (platinum)
- Temperature

Measurement range

High performance (S) glass

0 to 14 pH

Low temperature (LT) glass

0 to 10 pH

ORP

-2,000 to 2,000 mV

Temperature range

High performance (S) glass

0 to 100 °C (32 to 212 °F)

(typical glass impedance at 25 °C [77 °F] = 250 MΩ)

Low temperature (LT) glass

-5 to 50 °C (23 to 122 °F)

(typical glass impedance at 25 °C [77 °F] = 25 MΩ)

ORP platinum electrode

0 to 60 °C (32 to 140 °F)

Temperature sensor

Pt1000 (Class B, IEC 60751)

Maximum pressure

Atmospheric

Recommended minimum sample conductivity

0.055 μS/cm

Recommended sample flowrate

100 to 500 mL/min

Recommended sensor storage

Between 15 and 35 °C (59 and 95 °F)

Isothermal point at 25 °C (77 °F)

pH 7

Reference system

Flowing KCl electrolyte with Ag/AgCl double junction

Process connections

PG 13.5

Wetted materials

Electrode body

Glass

Reference junction system

Ceramic

Measure system

pH: Glass

ORP: Platinum

Approvals, certification and safety

CE Mark

Covers EMC+LV directives

(including latest version of EN61010)

Regulation 31

Drinking water approval: Complies to DWI Regulation 31(4)(b)

Additional tests: BS6920 parts 2.2 and 2.4 on all wetted parts

EMC

Meets requirements of IEC61326 for an industrial environment

Ordering information

700 ULTRA-D 12 mm flowing junction pH/ORP electrode (EZLink digital)	APS732/	XX	X	XX	Option
Sensor type					
pH – bullet glass for standard applications: high performance (S) glass		P2			
pH – low temperature (LT) glass		P4			
ORP (Redox) – platinum		R2			
Connection type					
EZLink digital			D		
Integral cable length					
None				00	
1 m (3.3 ft)				01	
3 m (10 ft)				03	
5 m (16 ft)				05	
10 m (33 ft)				10	

Optional order code

Add one or more of the following codes after the standard ordering information to select any additional options if required

Flowcell systems					
Panel-mounted system for ultrapure water applications					F05
Includes: flowcell, reservoir, flowmeter, flow alarm and calibration cup holder mounted on a stainless steel panel (¼ in NPT process connections)					
Stainless steel flowcell kit for ultrapure water applications					F01
Includes: flowcell, reservoir, calibration cup holder and mounting kit					
Polypropylene flowcell kit for general process applications					F02
Includes: flowcell, reservoir, calibration cup holder and mounting kit					
Operating instructions					
English					M5
EZLink digital extension cable					
1 m (3.3 ft)					E01
5 m (16.4 ft)					E05
10 m (32.8 ft)					E10
15 m (49.2 ft)					E15
25 m (82 ft)					E25
50 m (164 ft)					E50

Accessories

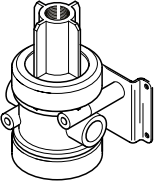
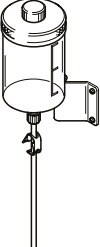
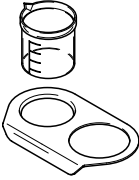
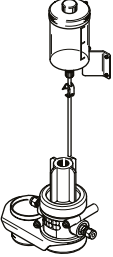
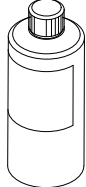
Part number	Description	
3KXA163000L0013	½ in NPT stainless steel flowcell + PG13.5 adapter	
3KXA163000L0014	½ in NPT polycarbonate flowcell + PG13.5 adapter	
3KXA163700L0001	Reservoir complete with mounting bracket assembly	
3KXA163000L0120	Calibration kit (includes calibration beaker and holder)	
3KXA163700L0005	½ in NPT stainless steel flowcell + reservoir + calibration kit	
3KXA163700L0006	½ in NPT polycarbonate flowcell + reservoir + calibration kit	
3KXA163700L0007	3.5 M KCl solution, 500 mL	

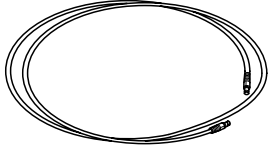
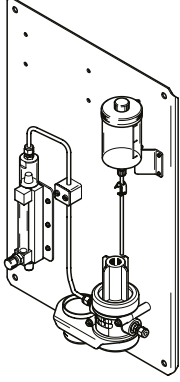
Part number	Description	
	EZLink cable	
AWT4009010	1 m (3.3 ft)	
AWT4009050	5 m (16.4 ft)	
AWT4009100	10 m (32.8 ft)	
AWT4009150	15 m (49.2 ft)	
AWT4009250	25 m (82 ft)	
AWT4009500	50 m (164 ft)	
3KXA163700L0002	700ULTRA panel assembly	

For a complete list of spares and accessories refer to Operating Instruction [OI/700](#).

Notes

Sales



Service



ABB Measurement & Analytics

For your local ABB contact, visit:
www.abb.com/contacts

For more product information, visit:
www.abb.com/measurement

We reserve the right to make technical changes or modify the contents of this document without prior notice. With regard to purchase orders, the agreed particulars shall prevail.
ABB does not accept any responsibility whatsoever for potential errors or possible lack of information in this document.

We reserve all rights in this document and in the subject matter and illustrations contained therein.
Any reproduction, disclosure to third parties or utilization of its contents – in whole or in parts – is forbidden without prior written consent of ABB.